

# S-5!<sup>®</sup>

## The Right Way!

The right way to attach almost anything to metal roofs!

## Installation Instructions

**Stop! Has your snow retention system been designed properly with the assistance of a distributor?**

**Notice to S-5!<sup>®</sup> product users:** Specific layout and assembly schematics for S-5! products are the responsibility of the user or project designer. Due to the many variables involved with specific panel products, climates, snow melt phenomena, and job particulars, the manufacturer cannot and does not express any opinions as to the suitability of any S-5! assembly for any specific application and assumes no liability with respect thereto. S-5! clamps are tested for ultimate holding strength on various seam types and materials. This information is available from S-5! distributors as well as from the S-5! website: [www.S-5.com](http://www.S-5.com). This document is an installation guide only and the photographs and drawings herein are for the purpose of illustrating installation, tools and techniques, not system designs. Information contained within is intended to apply to the document as a whole.

**DualClip II<sup>™</sup> and DualClip III<sup>™</sup> are optional components that can be added to your S-5! DualGard<sup>™</sup>, VersaGard<sup>™</sup>, or VersaGard<sup>™</sup> V snow retention system to further retard the migration of snow. DualClip II fits seams heights from 1" to 1-1/2" and VersaGards. DualClip III fits seams 1-3/4" to 3-1/4". When seam spacing is  $\leq 24"$  one DualClip is used between each seam on the first row of snow retention. When seam spacing is  $>24"$ , two clips should be used.**

## Tools Needed

- Screw Gun\*
- 5/16" Drive Socket (not included)

\*For time saving tool recommendations contact S-5!

## To Install DualClip

1. Ensure that the correct DualClip is being used (DualClip II or DualClip III) by checking that the rubber "foot" is resting properly on the panel surface when the DualClip is placed on the upper pipe. When applying downward pressure on the part, the toe should engage the surface of the panel just before the heel (Fig 1).
2. Center DualClip on the 1" pipe cross-member between two roof seams or VersaGard brackets when using one DualClip per panel. When using two DualClips per panel, space DualClips an equal distance from the seam or brackets and the other DualClip (Fig 2). **Important:** DualClip should be placed between panel striations not on top.
3. Secure the DualClip directly to the cross-member by driving the screw through the pre-punched slot of the DualClip at the location where the pipe touches the slot, using a 5/16" drive socket (Fig 3). Be careful not to overtighten the screws; if screw gun RPMs accelerate, it has likely been stripped out. If a fastener has been stripped, it is important to remove the fastener, shift the DualClip over slightly, and re-fasten. To avoid stripping, use a screw gun with adjustable torque clutch.

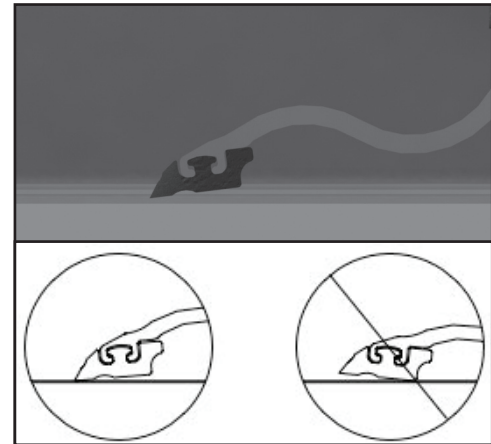

Fig 1: DualClip foot; toe engages panel before heel

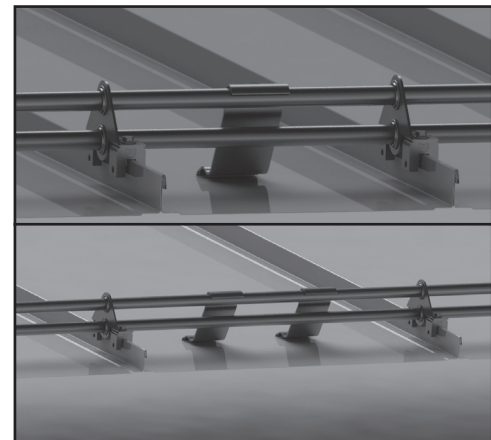

Fig 2: One or two DualClips spaced evenly between brackets and clamps

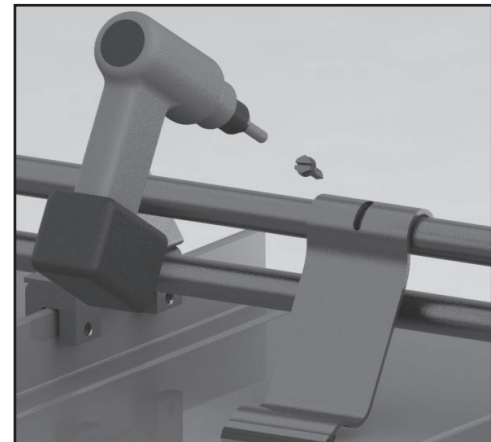

Fig 3: Fasten each DualClip to upper 1 inch pipe

These instructions are for use by those experienced in the trade. Always follow appropriate safety precautions and use appropriate tools.

**S-5!<sup>®</sup> Warning! Please use this product responsibly!**

Products are protected by multiple U.S. and foreign patents. For published data regarding holding strength, fastener torque, patents, and trademarks visit the S-5! website at [www.S-5.com](http://www.S-5.com). Copyright 2016, Metal Roof Innovations, Ltd. S-5! products are patent protected. S-5! aggressively protects its patents, trademarks, and copyrights.

DC23-v1.0-0816

DualClip<sup>™</sup> II & III Install

[www.S-5.com](http://www.S-5.com)

888-825-3432